

UNIT
7



Cultural Practices



LEARNING / FACILITATING MATERIALS

CITRUS PRODUCTION
NATIONAL CERTIFICATE I



CAADP



NEPAD
TRANSFORMING AFRICA



implemented by

giz Deutsche Gesellschaft
für Internationale
Zusammenarbeit (GIZ) GmbH



Introduction

Welcome to the start of your career in the cultural practices in citrus production.

A career in cultural practices of citrus has never been as popular as it is now; competition is strong and the standards are getting high. So you must aim higher, particularly if you see citrus industry as opportunity to build up your lifelong career. Many career options are also available within cultural practices in citrus production.

While training, you should make an effort on improving your personal habits, skill and knowledge to get along well with the working industry. All these aspects are essential to achieving success in the world of work.

Congratulations for making the decision to study cultural practices in citrus production. You have taken the first step towards a very interesting and satisfying career.

This learning material covers all the Learning Outcomes for cultural practices requirements for the Certificate I programme.

Table of Contents



CONTENT	PAGE NO
LO 1 Demonstrate knowledge in weed control management	3
a) Identify types of weed control	3
b) Identify appropriate tools and equipment for weed control	4
c) Demonstrate the appropriate methods for controlling weeds	5
d) Apply safety measures for controlling weeds	6
<hr/>	
LO 2 Demonstrate knowledge of crop nutritional requirements	8
a) State the nutritional requirements of citrus plants	8
b) Identify mineral deficiency symptoms in citrus	10
c) State the types of nutritional amendments	13
d) Identify the appropriate period for application of nutritional amendments	13
e) Measure the quantity of soil amendments for application	15
f) Demonstrate the safe methods of applying nutritional amendments to citrus plants	16
<hr/>	
LO 3 Demonstrate understanding of pruning citrus plants	16
a) Explain the benefits of pruning	19
b) Identify the appropriate tools and equipment for pruning	20
c) Describe the suitable period for pruning	22
d) Demonstrate the various methods of pruning	22
e) Apply safety measures in citrus pruning	24

Demonstrate knowledge of weed control management.

In this LO, you will learn to identify types of weed control, appropriate tools and equipment for weed control, demonstrate the appropriate methods for controlling weeds and apply safety measures for controlling weeds

PC (a) Identify types of weed control

Weed Control Management

Weed is an unwanted plant that grows in a particular area. Weeds affect the growth of plants in an area by competing with them for nutrients; this affect the growth, yields and quality of fruits hence the need to control them.

A plant is often termed a weed when it has one or more of the following characteristics:

- Little or no value (as in medicinal, nutritional, or energy)
- Very high growth rate and/or ease of germination
- Exhibits competition to crops, for space, light, water and nutrients

Weed control is the method of getting rid of unwanted plants on the farm or it is the method used to stop weeds from reaching a mature stage of growth when they could be harmful to domesticated plants.

There are several methods used in controlling weed and these can be categorized into four (4) main areas:

- a) Chemical
- b) Biological
- c) Mechanical
- d) Cultural

PC (b) Tools and Equipment used in the various weed control methods

With reference to the definition given, identify the tools in the table by their names

MANUAL



.....



.....

CHEMICAL



.....



.....

MECHANICAL



.....



.....

PC (c) Appropriate methods of weed control

Chemical Method of Weed Control

Chemical weed control refers to any technique that involves the application of a chemical (herbicide) to weeds or soil to control the germination or growth of the weed species. Simply, chemical weed control is the use of weedicide and herbicide to control weeds. In economic terms, chemical control of weeds is a very large industry and there are scores of examples of chemical weed control products. There are two main types of chemicals used in weed control. These are

- Selective (Atrazine, Select)
- Non-selective (Gramoxone- Paraquat, Glyphosates-(“Adwuma Wura”, “Ogyatana”, Caleherb, Round-up, Weed-out)

Biological Method of Weed Control

Biological weed control refers to any technique that involves the use of natural enemies of weed plants to control the germination of weed seeds or the spread of established plants. Simply put, biological method of weed control involves the use of animals, micro-organisms and plants to control weeds on the farm.

Examples of biological weed control include the use of small ruminants such as sheep and goats to control weed.



Often, the organism used is an insect or disease and a natural enemy of the weed.

Mechanical Method of Weed Control

Mechanical weed control refers to any technique that involves the use of farm equipment to control weeds i.e. it is the use of machines, tools and implements to control weeds on the farm.

Tillage, hoeing, mowing and burning are examples, but the two mechanical control techniques most often used are tillage and mowing. This is the oldest control method and is used most often worldwide.



To mulch or smother weeds often is considered mechanical, even though it simply excludes light rather than physically disrupting weed growth

Cultural Method of Weed Control

Cultural weed control refers to any technique that involves maintaining field conditions such

that weeds are less likely to become established and/or increase in number. This method decrease the target weed population and gives the seeded species or desired plant an opening in the environment to successfully germinate. Examples of cultural weed control would be crop rotation and hand-pulling. PC (d) Apply safety measures for controlling weeds

PC (d) Safety Measures in weed control

Safety is the state of being safe. It is the condition of being protected against physical or other types or consequences of failure, damage, error, accidents, harm or any other event which could be considered non-desirable.

Many of the weed control techniques involve dangerous and poisonous ways especially the use of herbicides (chemical weed control method: they can be absorbed very easily through the skin, by breathing the vapour, and by ingestion); h

<p>PERSONAL</p>	<p>OTHERS</p>
<ul style="list-style-type: none"> • Wear protective clothing: long sleeves, long pants, sturdy shoes, Gloves (chemical resistant), eye protection. • Always wear waterproof gloves. NB: A respirator is advised when mixing or pouring the liquid. • Do not eat, drink or smoke while using herbicide • Clean up any spills, including on your skin, with large amounts of water, or by shovelling up contaminated soil and disposing of it at the tip 	<ul style="list-style-type: none"> • Use indications to direct or inform others. • Train other workers or people how to safely use tools, equipment and also techniques involved in weed control. • Keep children and pets away.
<p>ENVIRONMENT</p>	<p>TOOLS and EQUIPMENT</p>
<ul style="list-style-type: none"> • Take note of water bodies in the area. • Properly dispose of containers that usually contain chemicals. 	<ul style="list-style-type: none"> • Wash, clean, oil and disinfect tools and equipment used • Repair any malfunctioned tool or equipment



Self-assessment

PC (a)

1. Complete the table below

Type of weed control	Method of control
Biological	
Chemical	
Cultural	

PC (b)

1. Explain any two methods used for cultural weed control

.....

.....

.....

.....

PC (c)

2. Using the chemical control method and observing the appropriate safety measures, demonstrate how to control weeds.

Demonstrate knowledge of crop nutritional requirements

In this LO, you will learn about the nutritional requirements of citrus plant, state the types of nutritional amendments, identify mineral deficiency symptoms, identify the appropriate period for application of nutritional amendments and measure the quantity of soil amendments for application.

PC (a) State the nutritional requirements of citrus plants

Citrus Nutritional Requirements

Nutrients are elements or compounds essential for animal and plant growth. It is also a source of nourishment processed by plants to give energy and build tissue. To encourage healthy, vigorous growth and desirable fruit characteristics, citrus trees must receive adequate water, drainage, sunlight and nutrients.

Some nutrients are capable of being moved around within the same plant and some examples are Nitrogen and Phosphorus. Such nutrients are described as “mobile”. Others such as Magnesium constitute the structural elements and are referred to as “immobile”

Nutrients required by citrus and other plants are generally classified as:

- Macronutrients
- Micronutrients



Both types are essential, but macronutrients are needed in larger quantities and citrus trees are far more likely to require supplemental applications of these elements.

Macronutrients for Citrus

Macronutrients include nitrogen, phosphorus, potassium, calcium, magnesium and sulphur. Nitrogen (**N**) has the greatest effect on citrus growth and appearance. It is the element used most to produce leaves, flowers and fruit.

Phosphorus (**P**), particularly concentrated in younger tissue, helps the citrus store and use energy and take in nutrients; it is also essential for cell division and growth. The correct balance of phosphorus to other nutrients is critical. It is particularly important during early stage of plant growth.

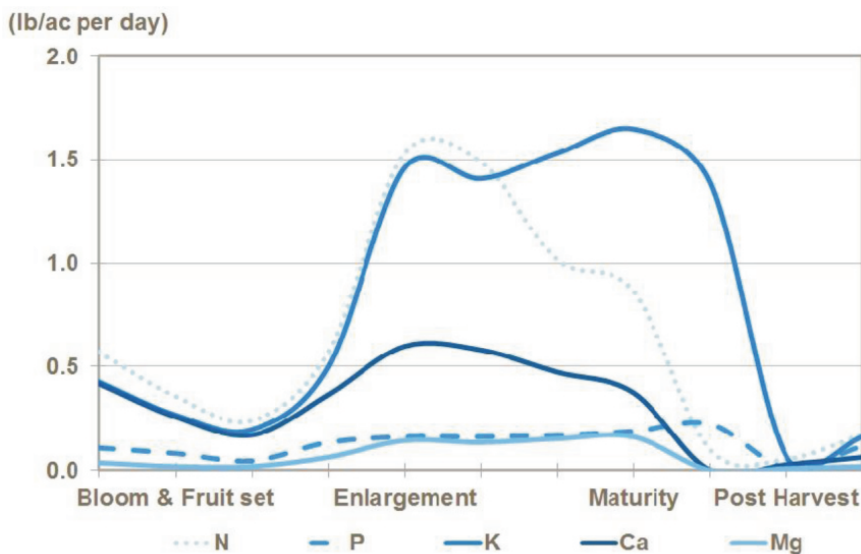

Relative macronutrients requirements for citrus per day at various stages

Potassium (**K**) and calcium (**Ca**) are used in relatively great amounts by citrus to produce leaves, flowers and fruits. Potassium is one of the most critical nutrients for increasing citrus tree growth and crop yields. During maturation, potassium demand increases in the fruit.

Calcium nutrition is also important, particularly during the early stages of growth and throughout fruit enlargement. Potassium nitrate is the preferred fertilizer during fruit growth, along with calcium nitrate.

Magnesium (**Mg**) is crucial in photosynthesis and stimulates phosphorus uptake, while sulphur is a part of many proteins and improves root growth and hardiness. Magnesium can be maintained at a constant rate throughout the season.

Micronutrients for Citrus

These are nutrients required by citrus in smaller quantities, sometimes referred to as trace or minor elements. Micronutrients are needed to satisfy yield and quality crop production and correct balance of these trace elements is essential.

Iron (**Fe**), Zinc (**Zn**), Manganese (**Mn**), Molybdenum (**Mo**) and Boron (**Bo**) are the micronutrients needed in the largest quantities to ensure growth quality.

Summary of functions of micronutrients

- Iron (**Fe**) is important for the production of chlorophyll
- Zinc (**Zn**) plays a role in carbon metabolism
- Boron (**Bo**) is important for sugar translocation, flowering and fruiting processes.
- Manganese (**Mn**) is essential for making nitrates usable.
- Copper (**Cu**) plays a role in several systems and processes.
- Molybdenum (**Mo**) assists in vitamin and starch formation.

PC (b) Identify mineral deficiency symptoms in citrus

The table below shows the mineral deficiency symptoms in citrus with pictures to facilitate understanding

MINERAL DEFICIENCY SYMPTOMS IN CITRUS



Nitrogen Deficiency

- Occurs on older leaves first then toward the younger leaves
- Light yellowish to green leaves. Mature leaves slowly bleach to a mottled irregular green and yellow pattern, become entirely yellow and then are shed
- Fruit peel is pale and smooth

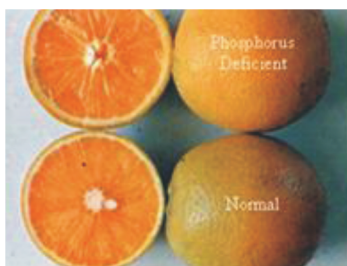

Phosphorus Deficiency

- Occurs on older leaves first
 - Leaves are small and narrow with purplish or bronze discoloration
 - Fruit drops before normal harvesting time, hollow core and thicker peel
 - Fruits are rather coarse with thick rinds and have lower juice content which is higher in acid
-



Potassium Deficiency

- Occurs on older leaves first
- Yellowing of the tips and margins and gets broader
- Smaller fruit size and early fruit drop
- stunted growth



Calcium Deficiency

- Occurs on mature leaves with young leaves appearing normal
- Leaves lose colour along the leaf margins and between the main veins
- Fruit is undersized and misshapen



Magnesium Deficiency

- Occurs on mature leaves with young leaves appearing normal
- Inverted green V-shape surrounded by yellowing
- dark green bands along the midrib and main veins surrounded by light green interveinal areas'
- Fruit yield and quality is reduced; seedy varieties are more affected.



Sulphur Deficiency

- Occurs on new growth
- Pale green to yellow in colour
- Fruit peel is pale and smooth



Iron Deficiency

- Occurs on young leaves
- Green veins with the leaf appearing light yellowish to white in colour
- Small fruit



Manganese Deficiency

- Occurs on young leaves
- Dark green veins with a lighter green background
- Small soft fruit

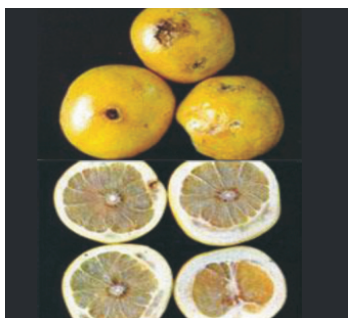

Boron Deficiency

- Occurs on younger leaves first
- Leaves show small water-soaked spots
- Fruit becomes hard and dry
- Darkish-coloured spots in the white albedo of fruit and sometimes in the central core



Copper Deficiency

- Occurs on new growth first
- Leaves are uniform in colour, long- willow looking leaves, bushy appearance and dieback
- Fruit splitting and gumming
- Twigs can develop blister-like pockets of clear gum at nodes



Molybdenum Deficiency

- Occurs on mature leaves first
- Interveinal chlorotic spots in early summer
- Under severe conditions, fruit has large irregular brown spots surrounded with yellow discoloration

PC (c) State the types of nutritional amendments

Types of Nutritional Amendments

There are two types of nutritional amendments:

- Organic
- Inorganic

Organic nutritional amendments: are derived from plants or plant products that occur naturally, or are the by-products of processing plants or mills (sawdust, cedar chips, bark, bagasse, rice hulls) or waste disposal plants (compost).

Basically, **organic amendments** come from something that was alive **whiles inorganic amendments**, on the other hand, are either mined or man-made. Inorganic nutritional amendments include chemical fertilizers that may be applied through foliar spraying or as pellets per the soil.

PC (d) Identify the appropriate period for application of nutritional amendment.



Period for nutritional amendment application

Two-thirds of the nutritional amendment should be applied to citrus each year between January and early June, timed so that nutrients are available during the flowering and fruit-setting period. The remaining one-third can be applied in September or October. Split fertilizer applications or fertigation combined with sound irrigation management increase fertilizer efficiency by consistently supplying nutrients and reducing leaching if unexpected rain occurs. With these circumstances, less fertilizer is required. Fertilizer reduction can also be realized by targeted placement within the root zone, timing applications to avoid rainy periods.



A balanced fertilizer that contains nitrogen, phosphorus and potassium or solely nitrogen fertilizer is generally applied to 3-year-old trees at a rate of about 1/2-pound annually.

However, nutritional amendment must be carried out during the various growth stages in citrus as shown below;

GROWTH STAGE	REQUIRED NUTRITIONAL AMENDMENT AND IMPORTANCE
 <p>Seedling</p>	<p>Phosphorus - for cell division and growth Sulphur - improves root growth and hardiness. Iron - is important for the production of chlorophyll</p>
 <p>Flowering</p>	<p>Nitrogen - boosts yield and tree productivity Phosphorus - maintains long-term productivity Potassium - establishes good early growth Calcium - aid leaf growth, pollination and fruit set</p>
 <p>Fruit Set</p>	<p>Nitrogen - maintains leaf growth and flowering Potassium and Magnesium - support strong growth Calcium - enhances fruit productivity and quality Sulphur - improves fruit set and fruit retention Zinc, Manganese and Iron - maintain fruit yield and quality Boron - minimizes fruit drop, prevents fruit deformities or storage problems of peel breakdown</p>



Nitrogen - maintains yield, improves skin thickness and fruit acidity

Potassium - maximizes fruit size, skin quality and vitamin C content

Calcium - boosts leaf growth and tree vigor and reduces skin disorders including fruit splitting and albedo breakdown

PC (e) Measure the quantity of nutritional amendment for application

Nutritional amendment application can also be used when nutritional deficiency has been detected or when there is low amount of a particular nutrient in the soil based on soil analysis. Where there is higher or excess availability of the element, it is advisable to correct that situation.

The table below is a guide to nutrient level requirements of the soil in citrus production

Element	Deficient less than	Low	Satisfactory	High	Excess more than
Nitrogen (N) (%)	2.2	2.2-2.4	2.5-2.8	2.9-3.2	3.3
Phosphorus (P) (%)	0.09	0.09-0.11	0.12-0.17	0.18-0.29	0.30
Potassium (K) (%)	0.7	0.7-1.1	1.2-1.7	1.8-2.3	2.4
Calcium (Ca) (%)	1.5	1.5-2.9	3.0-5.0	5.1-6.9	7.0
Magnesium (Mg) (%)	0.20	0.20-0.29	0.30-0.50	0.51-0.70	0.80
Sulfur (S) (%)	0.14	0.14-0.19	0.20-0.40	0.41-0.60	0.60
Iron (Fe) (ppm)	35	35-59	60-120	121-200	250
Boron (B) (ppm)	20	20-35	36-100	101-200	250
Manganese (Mn) (ppm)	18	18-24	25-100	101-300	500
Zinc (Zn) (ppm)	18	18-24	25-100	101-300	300
Copper (Cu) (ppm)	4	4-5	6-16	17-20	20
Molybdenum (Mo) (ppm)	0.06	0.06-0.09	0.1-1.0	2-50	50

Source: www.crec.ifas.ufl.edu/extension/trade.../2013/2013_June_fertilizer.pdf, 2014

PC (f) Demonstrate the safe method of applying nutritional amendments to citrus plants.

Methods of nutritional amendment application

Proper nutritional amendment application results in higher yields and minimizes environmental effects.

In citrus farming, the following amendment methods may be used;

Broadcasting: This is the even and uniform spreading of manure or fertilizers by hand over the entire surface of field. Broadcasting of nutritional amendment is done at planting or sowing of the citrus.

Top dressing: It is the spreading of fertilizers in the standing crop after basal application.

Foliar application: Citrus plants can absorb a small amount of nutrients from dilute solutions sprayed on to the leaves. Since the amount of micronutrients needed by plants is very small, these can be supplied as foliar sprays. Foliar applications are the best method we know of to get more calcium into fruit tissue to reduce post-harvest disorders



Liquid application: Water-soluble fertilizer can be applied with spray cans, sprinklers or furrow irrigation

Placement: In this method, the fertilizer is placed in the soil irrespective of the position of seed, seedling or growing plant before or after sowing of the crop. It may also be applied between plants with a row or between rows.

Ring method: Here, the fertilizer is applied in a circle with the radius of about 100cm from the base of the plants.



Self-assessment

PC (b)

1. Complete the table below by supplying the necessary information in the space provided.

Minerals Deficiency	Symptoms	Nutritional amendment required
Nitrogen		
Calcium		
Potassium		
Phosphorus		
Copper		

PC (d) (e) & (f)

1. Visit a nearby citrus farm and identify the growth stages in citrus plants and suggest the nutritional amendments to be applied. Use the table below

Growth Stage	Amendments to apply	Personal safety measure
1.		
2.		
3.		
4.		

Demonstrate understanding in pruning citrus plants.

In this LO, you will learn about the benefits, the appropriate tools and equipment, the suitable period, the various methods and the application of safety measures in citrus pruning.

PC (a) Explain the benefits of pruning

Pruning is the act of removing dead, diseased, side shoots and other undesirable branches from a woody plant. It can also be a practice involving the selective removal of parts of a plant, such as branches, buds or roots. The practice entails targeted removal of diseased, damaged, dead, non-productive and unwanted parts or branches from a plant.

Reasons for pruning citrus plants shall include the following

- i. trimming the plant,
- ii. maintaining plant health
- iii. improving the quality of flowers, fruits, foliage, stem
- iv. restricting growth.

Benefits of Pruning

Citrus trees are pruned in order to:

- allow light penetration into the canopy
- prevent crowding of main scaffold branches and to remove branches which cross
- remove or shorten water shoots to prevent them from becoming too dominant
- allow air circulation and access under trees (skirt pruning)
- increase fruit size
- prevent fruit damage due to limb rubbing.
- Easy harvesting



Note: Avoid over pruning. The leaves are the manufacturing part of the plant; removing too much of the canopy will reduce plant growth and fruit. Citrus bark burns easily if over exposed to the sun.

PC (b) Identify the appropriate tools and equipment for pruning

Pruning Tools/Equipment

THE PICTURES BELOW SHOW SOME TOOLS USED IN PRUNING

Hand shears



Scissors



Anvil

Pruning shears are good for branches up to 1/2-inch in diameter. Attempting to cut larger branches risks making a poor cut and/or ruining the shears.

There are two types of hand shears: anvil cut and scissor action. In the anvil type, a sharpened blade cuts against a broad flat plate. In the scissor type, a thin sharp blade slides closely past a thicker (but also sharp) blade. The scissor type is usually expensive, but makes cleaner and closer cuts. Whereas the anvil type, unless very sharp crushes plant tissue as it cuts.

Lopping Shears



Lopping shears have long handles and are operated with both hands. Even the cheapest can cut 1/2-inch diameter material. The better ones can slice through branches of 2 inches or more depending on species and condition. Lopping shears also are available in anvil and scissor types. Again, the scissor cut is better than anvil cut lopping shears.

Combination Pole Saw-Pruner



Pole pruners have a cutter with one hooked blade above and a cutting blade beneath. The cutter is on a pole and is operated by a lanyard pulled downward. The poles can

either be in sections that fit together or telescoping and can be made of several materials. Wooden poles are heavy; aluminium poles are light and can conduct electricity if they touch an overhead wire. Fibreglass or some type of plastic compound is probably the best. Poles can be fitted with saws but these are usually very frustrating to use.

Use of pole pruners can be dangerous, as material cut overhead may fall on the operator unless it hangs up in other branches. Exercise caution and wear head and eye protection.

Hedge Shears

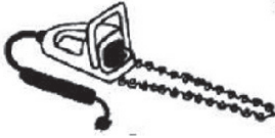

- Hedge shears have long flat blades and relatively short handles. Heavy-duty shears with one blade serrated are good for difficult jobs.

Pruning Saw



Fineness of cutting edge is measured in points (teeth per inch). An 8-point saw is for delicate, close work on small shrubs and trees. Average saws are normally 6 points, while 4 ½-point saws are for fairly heavy limbs.

A fixed-blade saw with a leather scabbard is safer and easier to use. Folding saws either require a screwdriver (for a slotted-head holding screw) or will have a protruding wing nut, which can scar the trunk when a limb is cut. If the saw suddenly folds while in use, the operator's fingers can be injured.

Blades can be either straight or curved. Many prefer a curved blade that cuts on the draw stroke. A double-edged saw has fine teeth on one side, coarse on the other; will be difficult to use in densely branched plants.

Bow Saw

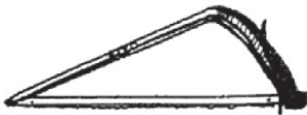

Bow saws are good only where no obstruction exists for a foot or more above the area to be cut.



Note: All pruning tools should be sharp and clean. Generally, sterilizing pruners is unnecessary when dealing with soil or airborne bacterial and fungal pathogens because the operator's clothing is much more likely sources of contamination.

PC (c) Describe the suitable period for pruning

Period for pruning

If pruning is to rejuvenate then prune a short time before a major growth flush. Pruning must be done before flowering and after harvesting.

PC (d) Demonstrate the various methods of pruning

Methods of pruning

General Maintenance Pruning: This helps to remove discoloured, damaged or dead wood from trees as necessary throughout the year. It is also a method of removing crossing branches or branches that shade out lower branches.

Suckering: Shoots below the bud union are removed as soon as they appear. These shoots grow from the rootstock and will not be productive.

Gourmands: Water sprouts or gourmands are long, thick and very vigorous branches that seem to suddenly appear in the canopy. These branches grow very rapidly and use large amounts of nutrients and water but remain vegetative for a number of years.

If they do produce fruits, it's often poor in quality, size and rough and with dry segments known as "uglies." Gourmands contribute little to the productive capacity of the tree, so they should be removed at the base.

Pruning for Pest Management: Citrus pests include many soft bodied sucking insects such as scale and mealy bugs. These insects thrive in dense canopies with high humidity and little air movement.

The dense canopy may also impede the ability of predators and parasitoids to find the pest insects. Thinning the canopy significantly reduce insect pest populations to the point that insecticide sprays are unnecessary.

Skeleton pruning: Is normally a last resort with old trees to get a few more years from them. Cut back all shoots leaving only the main scaffold branches. The scaffold branches should be white washed with a lime mixture or watered down white acrylic paint to protect the bark from sun burn until the tree refurbishes itself.

Skirting Up: Some citrus trees have pendulous branches that hang to the ground. These are called skirt branches and they can impede weeding, fertilizer/compost application and provide pathways for ant populations to use the trees.

With heavy fruit loads, these branches bend and fruit may touch the ground. Fruit may then be contaminated by soil borne pathogens. Trees should be skirted up to 18 – 24 inches (75 cm) above the ground every couple of years.



Machine hedging (side hedging and flat topping) involves the use of heavy machines in pruning. There will always be some fruit loss when using machine hedging.

The benefits of improved access and increased fruit size have to be weighed against the crop loss and the cost of the operation.

Side hedging can be done at an angle of 15o to 25o from the vertical to allow better light penetration to the lower parts of the canopy. Trees can be hedged at 25o to form a triangular shape and then flat topped as shown in **Figure 1** below.



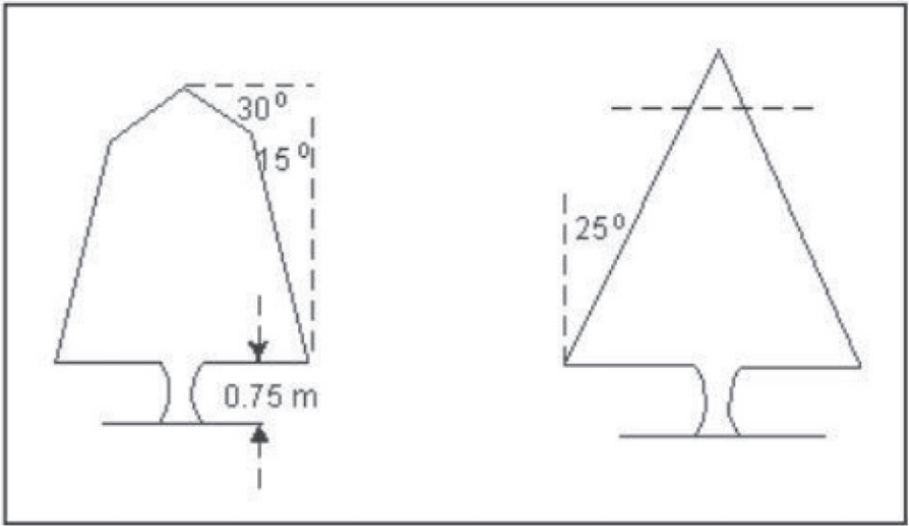

FIGURE 1

Machine pruning can be carried out over a three year period by pruning one side in a particular year, the other side the following year and the top the year after. This reduces crop losses in the year the activity was carried out.

PC (e) Apply safety measures in citrus pruning

Safety measures

In the table below are some safety measures to be observed when pruning citrus plants.

PERSONAL	TOOLS	OTHERS
<ul style="list-style-type: none"> Wear protective clothing: long sleeves, trousers, strong boots, gloves and goggles. 	<ul style="list-style-type: none"> Wash, clean, oil tools and equipment used in pruning. Right tool must be used for right job. Repair any malfunctioning tool before usage. 	<ul style="list-style-type: none"> Use indications to direct or inform others. Train other workers or people on how to safely use tools, equipment and techniques involved in pruning.

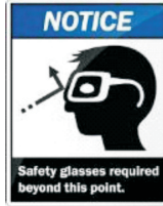

Self-assessment

You have been asked by your headmaster to control the growth of parasitic plants on citrus trees in the school's citrus plantation

PC (a)

1. Discuss any four benefits of pruning the citrus trees

.....
.....
.....
.....

PC (b), (c) & (d)

1. Using the appropriate tools, demonstrate how you will prune citrus plants in the school farm during a suitable period.

PC (e)

1. Complete the table below by providing the suitable equipment used for protection when pruning citrus plants.

Body part	Safety equipment needed
Eye	
Feet	
Hands	

